

JEE 2023 Session-1 24th Jan to 1st Feb 2023

Application No	
Candidate Name	
Roll No	
Test Date	29/01/2023
Test Time	9:00 AM - 12:00 PM
Subject	B TECH

Section : Physics Section A

Q.1 A stone is projected at angle 30° to the horizontal. The ratio of kinetic energy of the stone at point of projection to its kinetic energy at the highest point of flight will be -

- Options
1. 1 : 4
 2. 4 : 1
 3. 1 : 2
 4. 4 : 3

Question Type : MCQ
 Question ID : 3666942015
 Option 1 ID : 3666946233
 Option 2 ID : 3666946236
 Option 3 ID : 3666946234
 Option 4 ID : 3666946235
 Status : Answered
 Chosen Option : 2

Q.2 Match List I with List II:

List I (Physical Quantity)	List II (Dimensional Formula)
A. Pressure gradient	I. $[M^2L^2T^{-2}]$
B. Energy density	II. $[ML^{-1}T^{-2}]$
C. Electric Field	III. $[ML^{-2}T^{-2}]$
D. Latent heat	IV. $[M^1L^1T^{-3}A^{-1}]$

Choose the **correct** answer from the options given below:

- Options
1. A-III, B-II, C-I, D-IV
 2. A-III, B-II, C-IV, D-I
 3. A-II, B-III, C-I, D-IV
 4. A-II, B-III, C-IV, D-I

Question Type : MCQ
 Question ID : 3666942007
 Option 1 ID : 3666946203
 Option 2 ID : 3666946204
 Option 3 ID : 3666946201
 Option 4 ID : 3666946202
 Status : Answered
 Chosen Option : 2

- Q.3 Find the mutual inductance in the arrangement, when a small circular loop of wire of radius ' R ' is placed inside a large square loop of wire of side L ($L \gg R$). The loops are coplanar and their centres coincide :

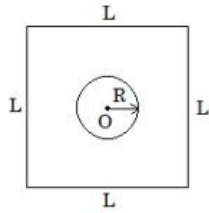

Options

1. $M = \frac{2\sqrt{2}\mu_0 R}{L^2}$
2. $M = \frac{\sqrt{2}\mu_0 R}{L^2}$
3. $M = \frac{\sqrt{2}\mu_0 R^2}{L}$
4. $M = \frac{2\sqrt{2}\mu_0 R^2}{L}$

Question Type : MCQ

Question ID : 3666942012

Option 1 ID : 3666946222

Option 2 ID : 3666946224

Option 3 ID : 3666946223

Option 4 ID : 3666946221

Status : Not Answered

Chosen Option : --

- Q.4 If the height of transmitting and receiving antennas are 80 m each, the maximum line of sight distance will be

Given: Earth's radius = 6.4×10^6 m

- Options
1. 36 km
 2. 28 km
 3. 64 km
 4. 32 km

Question Type : MCQ

Question ID : 3666942023

Option 1 ID : 3666946267

Option 2 ID : 3666946266

Option 3 ID : 3666946268

Option 4 ID : 3666946265

Status : Not Answered

Chosen Option : --

Q.5

In a cuboid of dimension $2L \times 2L \times L$, a charge q is placed at the center of the surface 'S' having area of $4L^2$. The flux through the opposite surface to 'S' is given by

Options

1. $\frac{q}{6\epsilon_0}$

2. $\frac{q}{12\epsilon_0}$

3. $\frac{q}{3\epsilon_0}$

4. $\frac{q}{2\epsilon_0}$

Question Type : MCQ

Question ID : 3666942008

Option 1 ID : 3666946206

Option 2 ID : 3666946207

Option 3 ID : 3666946205

Option 4 ID : 3666946208

Status : Answered

Chosen Option : 2

Q.6

If a radioactive element having half-life of 30 min is undergoing beta decay, the fraction of radioactive element remains undecayed after 90 min. will be

Options

1. $\frac{1}{4}$

2. $\frac{1}{16}$

3. $\frac{1}{2}$

4. $\frac{1}{8}$

Question Type : MCQ

Question ID : 3666942025

Option 1 ID : 3666946274

Option 2 ID : 3666946276

Option 3 ID : 3666946273

Option 4 ID : 3666946275

Status : Not Attempted and
Marked For Review

Chosen Option : --

Q.7 A block of mass m slides down the plane inclined at angle 30° with an acceleration $\frac{g}{4}$. The value of coefficient of kinetic friction will be:

Options

1. $\frac{1}{2\sqrt{3}}$
2. $\frac{2\sqrt{3}-1}{2}$
3. $\frac{2\sqrt{3}+1}{2}$
4. $\frac{\sqrt{3}}{2}$

Question Type : MCQ

Question ID : 3666942016

Option 1 ID : 3666946239

Option 2 ID : 3666946237

Option 3 ID : 3666946238

Option 4 ID : 3666946240

Status : Answered

Chosen Option : 4

Q.8 A bicycle tyre is filled with air having pressure of 270 kPa at 27°C . The approximate pressure of the air in the tyre when the temperature increases to 36°C is

Options

1. 278 kPa
2. 360 kPa
3. 262 kPa
4. 270 kPa

Question Type : MCQ

Question ID : 3666942021

Option 1 ID : 3666946259

Option 2 ID : 3666946260

Option 3 ID : 3666946257

Option 4 ID : 3666946258

Status : Answered

Chosen Option : 3

- Q.9** In a Young's double slit experiment, two slits are illuminated with a light of wavelength 800 nm. The line joining A_1P is perpendicular to A_1A_2 as shown in the figure. If the first minimum is detected at P , the value of slits separation 'a' will be:

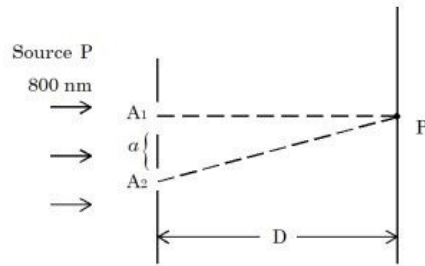

The distance of screen from slits $D = 5 \text{ cm}$

- Options**
1. 0.2 mm
 2. 0.4 mm
 3. 0.5 mm
 4. 0.1 mm

Question Type : MCQ

Question ID : 3666942014

Option 1 ID : 3666946229

Option 2 ID : 3666946232

Option 3 ID : 3666946231

Option 4 ID : 3666946230

Status : Not Answered

Chosen Option : --

- Q.10** Ratio of thermal energy released in two resistors R and $3R$ connected in parallel in an electric circuit is :

- Options**
1. 3 : 1
 2. 1 : 1
 3. 1 : 27
 4. 1 : 3

Question Type : MCQ

Question ID : 3666942009

Option 1 ID : 3666946212

Option 2 ID : 3666946210

Option 3 ID : 3666946211

Option 4 ID : 3666946209

Status : Answered

Chosen Option : 2

Q.11 The threshold wavelength for photoelectric emission from a material is 5500 \AA . Photoelectrons will be emitted, when this material is illuminated with monochromatic radiation from a

- A. 75 W infra-red lamp
- B. 10 W infra-red lamp
- C. 75 W ultra-violet lamp
- D. 10 W ultra-violet lamp

Choose the correct answer from the options given below:

- Options
1. B and C only
 2. C only
 3. A and D only
 4. C and D only

Question Type : MCQ

Question ID : 3666942024

Option 1 ID : 3666946272

Option 2 ID : 3666946269

Option 3 ID : 3666946270

Option 4 ID : 3666946271

Status : Answered

Chosen Option : 2

downloaded from

StudentSuvidha.com

Q.12

A single current carrying loop of wire carrying current I flowing in anticlockwise direction seen from +ve z direction and lying in xy plane is shown in figure. The plot of \hat{j} component of magnetic field (B_y) at a distance ' a ' (less than radius of the coil) and on yz plane vs z coordinate looks like

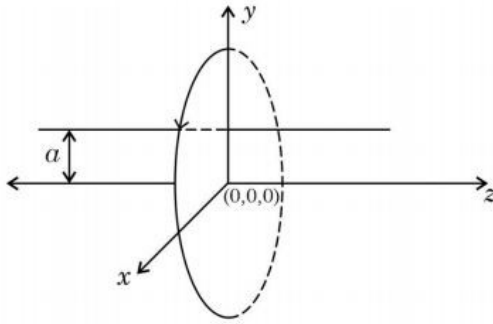

Options

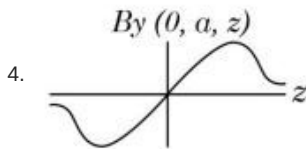
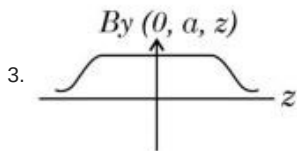
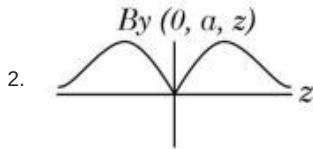
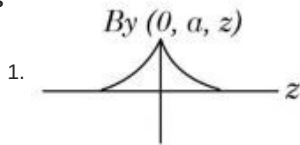

downloaded from
StudentSuvidha.com

Question Type : MCQ

Question ID : 3666942010

Option 1 ID : 3666946213

Option 2 ID : 3666946215

Option 3 ID : 3666946216

Option 4 ID : 3666946214

Status : Answered

Chosen Option : 4

Q.13 Which one of the following statement is not correct in the case of light emitting diodes?

- A. It is a heavily doped p-n junction.
- B. It emits light only when it is forward biased.
- C. It emits light only when it is reverse biased.
- D. The energy of the light emitted is equal to or slightly less than the energy gap of the semiconductor used.

Choose the correct answer from the options given below:

- Options
- 1. A
 - 2. B
 - 3. C and D
 - 4. C

Question Type : MCQ
 Question ID : 3666942026
 Option 1 ID : 3666946277
 Option 2 ID : 3666946278
 Option 3 ID : 3666946280
 Option 4 ID : 3666946279
 Status : Answered
 Chosen Option : 3

Q.14 Two particles of equal mass 'm' move in a circle of radius 'r' under the action of their mutual gravitational attraction. The speed of each particle will be :

- Options
- 1. $\sqrt{\frac{Gm}{r}}$
 - 2. $\sqrt{\frac{Gm}{2r}}$
 - 3. $\sqrt{\frac{4Gm}{r}}$
 - 4. $\sqrt{\frac{Gm}{4r}}$

Question Type : MCQ
 Question ID : 3666942018
 Option 1 ID : 3666946245
 Option 2 ID : 3666946247
 Option 3 ID : 3666946248
 Option 4 ID : 3666946246
 Status : Answered
 Chosen Option : 3

- Q.15 The magnitude of magnetic induction at mid point O due to current arrangement as shown in Fig will be

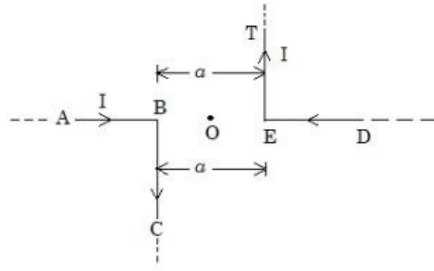

- Options
1. $\frac{\mu_0 I}{2\pi a}$
 2. 0
 3. $\frac{\mu_0 I}{\pi a}$
 4. $\frac{\mu_0 I}{4\pi a}$

Question Type : MCQ

Question ID : 3666942011

Option 1 ID : 3666946220

Option 2 ID : 3666946217

Option 3 ID : 3666946218

Option 4 ID : 3666946219

Status : Not Attempted and
Marked For Review

Chosen Option : --

- Q.16 A person observes two moving trains, 'A' reaching the station and 'B' leaving the station with equal speed of 30 m/s. If both trains emit sounds with frequency 300 Hz, (Speed of sound: 330 m/s) approximate difference of frequencies heard by the person will be.

- Options
1. 55 Hz
 2. 80 Hz
 3. 33 Hz
 4. 10 Hz

Question Type : MCQ

Question ID : 3666942022

Option 1 ID : 3666946262

Option 2 ID : 3666946264

Option 3 ID : 3666946263

Option 4 ID : 3666946261

Status : Answered

Chosen Option : 2

Q.17 Given below are two statements: One is labelled as **Assertion A** and the other is labelled as **Reason R**.

Assertion A: If dQ and dW represent the heat supplied to the system and the work done on the system respectively. Then according to the first law of thermodynamics $dQ = dU - dW$.

Reason R: First law of thermodynamics is based on law of conservation of energy.

In the light of the above statements, choose the **correct** answer from the options given below:

- Options**
1. Both A and R are correct and R is the correct explanation of A
 2. A is correct but R is not correct
 3. A is not correct but R is correct
 4. Both A and R are correct but R is not the correct explanation of A

Question Type : MCQ

Question ID : 3666942020

Option 1 ID : 3666946253

Option 2 ID : 3666946255

Option 3 ID : 3666946256

Option 4 ID : 3666946254

Status : Answered

Chosen Option : 3

Q.18 Surface tension of a soap bubble is $2.0 \times 10^{-2} \text{ Nm}^{-1}$. Work done to increase the radius of soap bubble from 3.5 cm to 7 cm will be:

Take $\left[\pi = \frac{22}{7} \right]$

- Options**
1. $9.24 \times 10^{-4} \text{ J}$
 2. $5.76 \times 10^{-4} \text{ J}$
 3. $0.72 \times 10^{-4} \text{ J}$
 4. $18.48 \times 10^{-4} \text{ J}$

Question Type : MCQ

Question ID : 3666942019

Option 1 ID : 3666946249

Option 2 ID : 3666946251

Option 3 ID : 3666946250

Option 4 ID : 3666946252

Status : Not Answered

Chosen Option : --

Q.19 Which of the following are true?

- A. Speed of light in vacuum is dependent on the direction of propagation.
- B. Speed of light in a medium is independent of the wavelength of light.
- C. The speed of light is independent of the motion of the source.
- D. The speed of light in a medium is independent of intensity.

Choose the correct answer from the options given below:

- Options
- 1. A and C only
 - 2. B and C only
 - 3. B and D only
 - 4. C and D only

Question Type : MCQ
Question ID : 3666942013
Option 1 ID : 3666946225
Option 2 ID : 3666946226
Option 3 ID : 3666946227
Option 4 ID : 3666946228
Status : Answered
Chosen Option : 1

Q.20 A car is moving on a horizontal curved road with radius 50 m. The approximate maximum speed of car will be, if friction between tyres and road is 0.34. [take $g = 10 \text{ ms}^{-2}$]

- Options
- 1. 22.4 ms^{-1}
 - 2. 17 ms^{-1}
 - 3. 3.4 ms^{-1}
 - 4. 13 ms^{-1}

Question Type : MCQ
Question ID : 3666942017
Option 1 ID : 3666946244
Option 2 ID : 3666946242
Option 3 ID : 3666946241
Option 4 ID : 3666946243
Status : Answered
Chosen Option : 2

Section : Physics Section B

- Q.21** As shown in the figure, three identical polaroids P_1 , P_2 and P_3 are placed one after another. The pass axis of P_2 and P_3 are inclined at angle of 60° and 90° with respect to axis of P_1 . The source S has an intensity of $256 \frac{W}{m^2}$.

The intensity of light at point O is $\frac{W}{m^2}$.

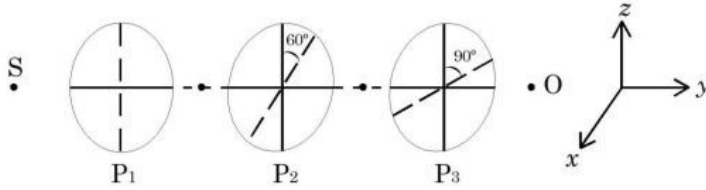

Given --
Answer :

Question Type : SA
Question ID : 3666942036
Status : Not Answered

- Q.22** A solid sphere of mass 2 kg is making pure rolling on a horizontal surface with kinetic energy 2240 J. The velocity of centre of mass of the sphere will be ms^{-1} .

Given --
Answer :

Question Type : SA
Question ID : 3666942030
Status : Not Answered

- Q.23** In a metre bridge experiment the balance point is obtained if the gaps are closed by 2Ω and 3Ω . A shunt of $X \Omega$ is added to 3Ω resistor to shift the balancing point by 22.5 cm. The value of X is _____

Given --
Answer :

Question Type : SA
Question ID : 3666942034
Status : Not Answered

- Q.24** Two simple harmonic waves having equal amplitudes of 8 cm and equal frequency of 10 Hz are moving along the same direction. The resultant amplitude is also 8 cm. The phase difference between the individual waves is _____ degree.

Given --
Answer :

Question Type : SA
Question ID : 3666942028
Status : Not Answered

- Q.25** A certain elastic conducting material is stretched into a circular loop. It is placed with its plane perpendicular to a uniform magnetic field $B = 0.8 \text{ T}$. When released the radius of the loop starts shrinking at a constant rate of 2 cm s^{-1} . The induced emf in the loop at an instant when the radius of the loop is 10 cm will be _____ mV.

Given --
Answer :

Question Type : SA
Question ID : 3666942035
Status : Not Answered

- Q.26** A point charge $q_1 = 4q_0$ is placed at origin. Another point charge $q_2 = -q_0$ is placed at $x = 12 \text{ cm}$. Charge of proton is q_0 . The proton is placed on x axis so that the electrostatic force on the proton is zero. In this situation, the position of the proton from the origin is _____ cm.

Given 12
Answer :

Question Type : SA
Question ID : 3666942033
Status : Answered

- Q.27** A radioactive element ${}_{92}^{242}\text{X}$ emits two α -particles, one electron and two positrons. The product nucleus is represented by ${}_{P}^{234}\text{Y}$. The value of P is _____

Given 92
Answer :

Question Type : SA
Question ID : 3666942027
Status : Answered

- Q.28** A tennis ball is dropped on to the floor from a height of 9.8 m . It rebounds to a height 5.0 m . Ball comes in contact with the floor for 0.2 s . The average acceleration during contact is _____ ms^{-2} .

(Given $g = 10 \text{ ms}^{-2}$)

Given 7
Answer :

Question Type : SA
Question ID : 3666942032
Status : Answered

- Q.29** A 0.4 kg mass takes 8 s to reach ground when dropped from a certain height 'P' above surface of earth. The loss of potential energy in the last second of fall is _____ J.

(Take $g = 10 \text{ m/s}^2$)

Given 1200
Answer :

Question Type : SA
Question ID : 3666942031
Status : Answered

Q.30 A body cools from 60°C to 40°C in 6 minutes. If, temperature of surroundings is 10°C. Then, after the next 6 minutes, its temperature will be _____°C.

Given 20
Answer :

Question Type : SA
Question ID : 3666942029
Status : Answered

Section : Chemistry Section A

Q.31 "A" obtained by Ostwald's method involving air oxidation of NH_3 , upon further air oxidation produces "B". "B" on hydration forms an oxoacid of Nitrogen along with evolution of "A". The oxoacid also produces "A" and gives positive brown ring test.

Identify A and B, respectively.

- Options
1. $\text{NO}_2, \text{N}_2\text{O}_5$
 2. NO, NO_2
 3. $\text{NO}_2, \text{N}_2\text{O}_4$
 4. $\text{N}_2\text{O}_3, \text{NO}_2$

Question Type : MCQ
Question ID : 3666942045
Option 1 ID : 3666946324
Option 2 ID : 3666946325
Option 3 ID : 3666946326
Option 4 ID : 3666946323
Status : Answered
Chosen Option : 1

Q.32 The reaction representing the Mond process for metal refining is _____.

- Options
1. $2\text{K}[\text{Au}(\text{CN})_2] + \text{Zn} \xrightarrow{\Delta} \text{K}_2[\text{Zn}(\text{CN})_4] + 2\text{Au}$
 2. $\text{ZnO} + \text{C} \xrightarrow{\Delta} \text{Zn} + \text{CO}$
 3. $\text{Zr} + 2\text{I}_2 \xrightarrow{\Delta} \text{ZrI}_4$
 4. $\text{Ni} + 4\text{CO} \xrightarrow{\Delta} \text{Ni}(\text{CO})_4$

Question Type : MCQ
Question ID : 3666942041
Option 1 ID : 3666946309
Option 2 ID : 3666946307
Option 3 ID : 3666946310
Option 4 ID : 3666946308
Status : Not Answered
Chosen Option : --

Q.33 During the borax bead test with CuSO_4 , a blue green colour of the bead was observed in oxidising flame due to the formation of

- Options
1. CuO
 2. Cu
 3. $\text{Cu}(\text{BO}_2)_2$
 4. Cu_3B_2

Question Type : MCQ
 Question ID : 3666942053
 Option 1 ID : 3666946358
 Option 2 ID : 3666946355
 Option 3 ID : 3666946356
 Option 4 ID : 3666946357
 Status : Answered
 Chosen Option : 1

Q.34 Compound that will give positive Lassaigne's test for both nitrogen and halogen is:

- Options
1. NH_4Cl
 2. $\text{NH}_2\text{OH}.\text{HCl}$
 3. $\text{CH}_3\text{NH}_2.\text{HCl}$
 4. $\text{N}_2\text{H}_4.\text{HCl}$

Question Type : MCQ
 Question ID : 3666942056
 Option 1 ID : 3666946368
 Option 2 ID : 3666946370
 Option 3 ID : 3666946369
 Option 4 ID : 3666946367
 Status : Not Answered
 Chosen Option : --

Q.35 Correct statement about smog is:

- Options
1. Classical smog also has high concentration of oxidizing agents
 2. Photochemical smog has high concentration of oxidizing agents
 3. Both NO_2 and SO_2 are present in classical smog
 4. NO_2 is present in classical smog

Question Type : MCQ
 Question ID : 3666942047
 Option 1 ID : 3666946334
 Option 2 ID : 3666946333
 Option 3 ID : 3666946332
 Option 4 ID : 3666946331
 Status : Answered
 Chosen Option : 3

Q.36

The correct order of hydration enthalpies is

- (A) K^+
- (B) Rb^+
- (C) Mg^{2+}
- (D) Cs^+
- (E) Ca^{2+}

Choose the correct answer from the options given below:

- Options
1. $E > C > A > B > D$
 2. $C > E > A > D > B$
 3. $C > A > E > B > D$
 4. $C > E > A > B > D$

Question Type : MCQ

Question ID : 3666942043

Option 1 ID : 3666946316

Option 2 ID : 3666946318

Option 3 ID : 3666946315

Option 4 ID : 3666946317

Status : Answered

Chosen Option : 2

Q.37

The standard electrode potential (M^{3+}/M^{2+}) for V, Cr, Mn & Co are -0.26 V, -0.41 V, $+1.57$ V and $+1.97$ V, respectively. The metal ions which can liberate H_2 from a dilute acid are

- Options
1. V^{2+} and Cr^{2+}
 2. Cr^{2+} and Co^{2+}
 3. V^{2+} and Mn^{2+}
 4. Mn^{2+} and Co^{2+}

Question Type : MCQ

Question ID : 3666942046

Option 1 ID : 3666946327

Option 2 ID : 3666946329

Option 3 ID : 3666946328

Option 4 ID : 3666946330

Status : Answered

Chosen Option : 1

Q.38 Number of cyclic tripeptides formed with 2 amino acids A and B is:

- Options
1. 2
 2. 4
 3. 5
 4. 3

Question Type : MCQ

Question ID : 3666942055

Option 1 ID : 3666946366

Option 2 ID : 3666946365

Option 3 ID : 3666946363

Option 4 ID : 3666946364

Status : Answered

Chosen Option : 1

Q.39 For 1 mol of gas, the plot of pV vs. p is shown below. p is the pressure and V is the volume of the gas

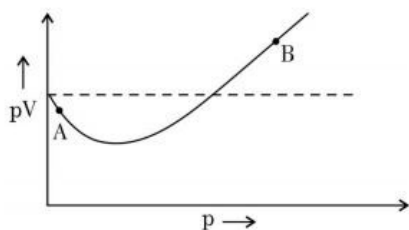

What is the value of compressibility factor at point A?

- Options
1. $1 - \frac{b}{V}$
 2. $1 + \frac{b}{V}$
 3. $1 - \frac{a}{RTV}$
 4. $1 + \frac{a}{RTV}$

Question Type : MCQ

Question ID : 3666942037

Option 1 ID : 3666946294

Option 2 ID : 3666946293

Option 3 ID : 3666946292

Option 4 ID : 3666946291

Status : Not Answered

Chosen Option : --

Q.40 Match List I with List II.

List I	List II
Antimicrobials	Names
(A) Narrow Spectrum Antibiotic	(I) Furacin
(B) Antiseptic	(II) Sulphur dioxide
(C) Disinfectants	(III) Penicillin G
(D) Broad spectrum antibiotic	(IV) Chloramphenicol

Choose the correct answer from the options given below:

- Options
- (A) – III, (B) – I, (C) – IV, (D) – II
 - (A) – III, (B) – I, (C) – II, (D) – IV
 - (A) – I, (B) – II, (C) – IV, (D) – III
 - (A) – II, (B) – I, (C) – IV, (D) – III

Question Type : MCQ

Question ID : 3666942054

Option 1 ID : 3666946361

Option 2 ID : 3666946362

Option 3 ID : 3666946360

Option 4 ID : 3666946359

Status : Answered

Chosen Option : 2

Q.41 Identify the correct order for the given property for following compounds.

- (A) Boiling Point: CCCCl < CCC(Cl)C < CC(C)CCl
- (B) Density: CCBr < CC(Cl)C < CC(I)C
- (C) Boiling Point: CCBr < CC(Br)C < CC(Br)(Br)C
- (D) Density: CC(I)C < CC(Br)C < CC(Cl)C
- (E) Boiling Point: CCCCl > CCC(Cl)C > CC(C)CCl

Choose the correct answer from the option given below:

- Options
- (A), (B) and (E) only
 - (A), (C) and (D) only
 - (B), (C) and (D) only
 - (A), (C) and (E) only

Question Type : MCQ

Question ID : 3666942049

Option 1 ID : 3666946339

Option 2 ID : 3666946341

Option 3 ID : 3666946340

Option 4 ID : 3666946342

Status : Answered

Chosen Option : 1

Q.42 Chiral complex from the following is:

Here en = ethylene diamine

- Options
1. cis – $[\text{PtCl}_2(\text{NH}_3)_2]$
 2. trans – $[\text{Co}(\text{NH}_3)_4\text{Cl}_2]^+$
 3. cis – $[\text{PtCl}_2(\text{en})_2]^{2+}$
 4. trans – $[\text{PtCl}_2(\text{en})_2]^{2+}$

Question Type : MCQ

Question ID : 3666942048

Option 1 ID : 3666946335

Option 2 ID : 3666946337

Option 3 ID : 3666946336

Option 4 ID : 3666946338

Status : Not Answered

Chosen Option : --

Q.43 Which of the following salt solutions would coagulate the colloid solution formed when FeCl_3 is added to NaOH solution, at the fastest rate?

- Options
1. 10 mL of $0.1 \text{ mol dm}^{-3} \text{Na}_2\text{SO}_4$
 2. 10 mL of $0.15 \text{ mol dm}^{-3} \text{CaCl}_2$
 3. 10 mL of $0.1 \text{ mol dm}^{-3} \text{Ca}_3(\text{PO}_4)_2$
 4. 10 mL of $0.2 \text{ mol dm}^{-3} \text{AlCl}_3$

Question Type : MCQ

Question ID : 3666942039

Option 1 ID : 3666946299

Option 2 ID : 3666946301

Option 3 ID : 3666946300

Option 4 ID : 3666946302

Status : Not Answered

Chosen Option : --

Q.44 The bond dissociation energy is highest for

- Options
1. Br_2
 2. F_2
 3. I_2
 4. Cl_2

Question Type : MCQ

Question ID : 3666942040

Option 1 ID : 3666946305

Option 2 ID : 3666946303

Option 3 ID : 3666946306

Option 4 ID : 3666946304

Status : Answered

Chosen Option : 3

Q.45 The shortest wavelength of hydrogen atom in Lyman series is λ . The longest wavelength in Balmer series of He^+ is

Options

1. $\frac{5}{9\lambda}$
2. $\frac{36\lambda}{5}$
3. $\frac{9\lambda}{5}$
4. $\frac{5\lambda}{9}$

Question Type : MCQ

Question ID : 3666942038

Option 1 ID : 3666946297

Option 2 ID : 3666946296

Option 3 ID : 3666946295

Option 4 ID : 3666946298

Status : Answered

Chosen Option : 3

Q.46 The magnetic behavior of Li_2O , Na_2O_2 and KO_2 , respectively, are

Options

1. diamagnetic, diamagnetic and paramagnetic
2. paramagnetic, paramagnetic and diamagnetic
3. paramagnetic, diamagnetic and paramagnetic
4. diamagnetic, paramagnetic and diamagnetic

Question Type : MCQ

Question ID : 3666942044

Option 1 ID : 3666946320

Option 2 ID : 3666946322

Option 3 ID : 3666946319

Option 4 ID : 3666946321

Status : Answered

Chosen Option : 2

Q.47 The major product 'P' for the following sequence of reactions is:

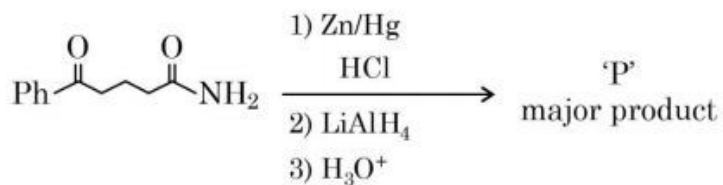

Options

- 1.
- 2.
- 3.
- 4.

Question Type : MCQ

Question ID : 3666942052

Option 1 ID : 3666946351

Option 2 ID : 3666946354

Option 3 ID : 3666946352

Option 4 ID : 3666946353

Status : Answered

Chosen Option : 4

Q.48 Which of the given compounds can enhance the efficiency of hydrogen storage tank?

Options

1. Li/P_4
2. Di-isobutylaluminium hydride
3. SiH_4
4. NaNi_5

Question Type : MCQ

Question ID : 3666942042

Option 1 ID : 3666946312

Option 2 ID : 3666946314

Option 3 ID : 3666946313

Option 4 ID : 3666946311

Status : Not Answered

Chosen Option : --

Q.49 Match List I with List II.

List I	List II
Reaction	Reagents
(A) Hoffmann Degradation	(I) Conc.KOH, Δ
(B) Clemenson reduction	(II) CHCl_3 , $\text{NaOH}/\text{H}_3\text{O}^{\oplus}$
(C) Cannizaro reaction	(III) Br_2 , NaOH
(D) Reimer-Tiemann Reaction	(IV) $\text{Zn-Hg}/\text{HCl}$

Choose the correct answer from the options given below:

- Options
- (A) – III, (B) – IV, (C) – I, (D) – II
 - (A) – III, (B) – IV, (C) – II, (D) – I
 - (A) – II, (B) – I, (C) – III, (D) – IV
 - (A) – II, (B) – IV, (C) – I, (D) – III

Question Type : MCQ

Question ID : 3666942051

Option 1 ID : 3666946347

Option 2 ID : 3666946349

Option 3 ID : 3666946348

Option 4 ID : 3666946350

Status : Answered

Chosen Option : 1

Q.50 The increasing order of pK_a for the following phenols is

- 2, 4 - Dinitrophenol
- 4 - Nitrophenol
- 2, 4, 5 - Trimethylphenol
- Phenol
- 3-Chlorophenol

Choose the correct answer from the option given below:

- Options
- (C), (E), (D), (B), (A)
 - (C), (D), (E), (B), (A)
 - (A), (B), (E), (D), (C)
 - (A), (E), (B), (D), (C)

Question Type : MCQ

Question ID : 3666942050

Option 1 ID : 3666946345

Option 2 ID : 3666946344

Option 3 ID : 3666946343

Option 4 ID : 3666946346

Status : Answered

Chosen Option : 4

Q.51

Following figure shows dependence of molar conductance of two electrolytes on concentration. Λ_m° is the limiting molar conductivity.

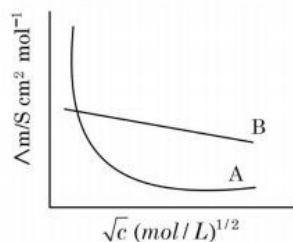

The number of **incorrect** statement(s) from the following is _____

- (A) Λ_m° for electrolyte A is obtained by extrapolation
 (B) For electrolyte B, Λ_m vs \sqrt{c} graph is a straight line with intercept equal to Λ_m°
 (C) At infinite dilution, the value of degree of dissociation approaches zero for electrolyte B.
 (D) Λ_m° for any electrolyte A or B can be calculated using λ° for individual ions

Given 2
 Answer :

Question Type : SA

Question ID : 3666942062

Status : Answered

Q.52

Consider the following reaction approaching equilibrium at 27°C and 1 atm pressure

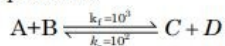

The standard Gibb's energy change ($\Delta_r G^\theta$) at 27°C is (-) _____ kJ mol⁻¹

(Nearest integer).

(Given: R = 8.3 J K⁻¹ mol⁻¹ and ln 10 = 2.3)

Given --
 Answer :

Question Type : SA

Question ID : 3666942059

Status : Not Answered

Q.53

Following chromatogram was developed by adsorption of compound 'A' on a 6 cm TLC glass plate. Retardation factor of the compound 'A' is _____ × 10⁻¹.

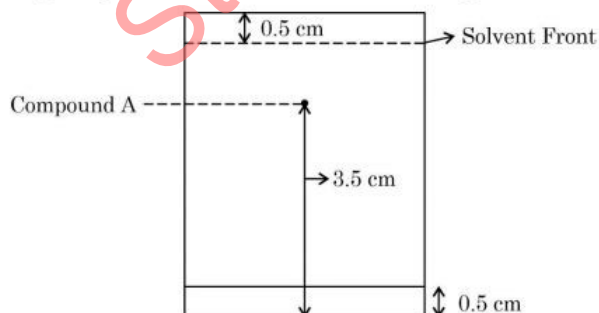

Given --
 Answer :

Question Type : SA

Question ID : 3666942065

Status : Not Answered

Q.54 The sum of bridging carbonyls in $W(CO)_6$ and $Mn_2(CO)_{10}$ is _____.

Given 2
Answer :

Question Type : SA
Question ID : 3666942064
Status : Answered

Q.55 The number of molecules or ions from the following, which do not have odd number of electrons are _____.

- (A) NO_2
- (B) ICl_4^-
- (C) BrF_3
- (D) ClO_2
- (E) NO_2^+
- (F) NO

Given --
Answer :

Question Type : SA
Question ID : 3666942058
Status : Not Answered

Q.56 Water decomposes at 2300 K

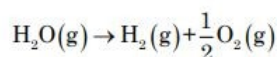

The percent of water decomposing at 2300 K and 1 bar is _____ (Nearest integer).

Equilibrium constant for the reaction is 2×10^{-3} at 2300 K.

Given --
Answer :

Question Type : SA
Question ID : 3666942061
Status : Not Answered

Q.57 Millimoles of calcium hydroxide required to produce 100 mL of the aqueous solution of pH 12 is $x \times 10^{-1}$. The value of x is _____ (Nearest integer).

Assume complete dissociation.

Given --
Answer :

Question Type : SA
Question ID : 3666942057
Status : Not Answered

Q.58 Solid Lead nitrate is dissolved in 1 litre of water. The solution was found to boil at 100.15°C . When 0.2 mol of NaCl is added to the resulting solution, it was observed that the solution froze at -0.8°C . The solubility product of PbCl_2 formed is _____ $\times 10^{-6}$ at 298 K. (Nearest integer)

Given : $K_b = 0.5 \text{ K kg mol}^{-1}$ and $K_f = 1.8 \text{ K kg mol}^{-1}$. Assume molality to be equal to molarity in all cases.

Given --
Answer :

Question Type : SA
Question ID : 3666942060
Status : Not Answered

Q.59 For certain chemical reaction $X \rightarrow Y$, the rate of formation of product is plotted against the time as shown in the figure. The number of **correct** statement/s from the following is _____

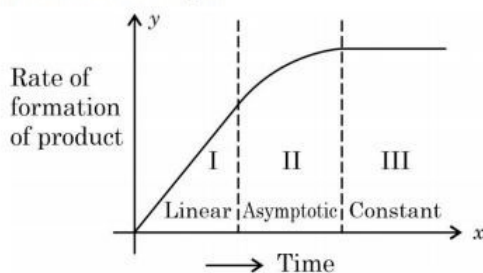

- (A) Over all order of this reaction is one
(B) Order of this reaction can't be determined
(C) In region I and III, the reaction is of first and zero order respectively
(D) In region-II, the reaction is of first order
(E) In region-II, the order of reaction is in the range of 0.1 to 0.9.

Given 2
Answer :

Question Type : SA
Question ID : 3666942063
Status : Marked For Review

Q.60 17 mg of a hydrocarbon (M.F. $\text{C}_{10}\text{H}_{16}$) takes up 8.40 mL of the H_2 gas measured at 0°C and 760 mm of Hg. Ozonolysis of the same hydrocarbon yields

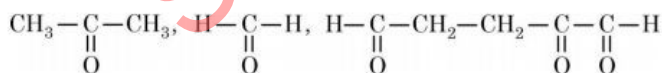

The number of double bond/s present in the hydrocarbon is _____.

Given 5
Answer :

Question Type : SA
Question ID : 3666942066
Status : Answered

Q.61 Three rotten apples are mixed accidentally with seven good apples and four apples are drawn one by one without replacement. Let the random variable X denote the number of rotten apples. If μ and σ^2 represent mean and variance of X , respectively, then $10(\mu^2 + \sigma^2)$ is equal to

- Options
1. 25
 2. 250
 3. 20
 4. 30

Question Type : MCQ
 Question ID : 3666942085
 Option 1 ID : 3666946454
 Option 2 ID : 3666946456
 Option 3 ID : 3666946453
 Option 4 ID : 3666946455
 Status : Answered
 Chosen Option : 2

Q.62 Let $x = 2$ be a root of the equation $x^2 + px + q = 0$ and

$$f(x) = \begin{cases} \frac{1 - \cos(x^2 - 4px + q^2 + 8q + 16)}{(x - 2p)^4}, & x \neq 2p \\ 0, & x = 2p \end{cases}$$

Then $\lim_{x \rightarrow 2p^+} [f(x)]$,

where $[\cdot]$ denotes greatest integer function, is

- Options
1. -1
 2. 1
 3. 2
 4. 0

Question Type : MCQ
 Question ID : 3666942073
 Option 1 ID : 3666946407
 Option 2 ID : 3666946408
 Option 3 ID : 3666946405
 Option 4 ID : 3666946406
 Status : Answered
 Chosen Option : 1

Q.63

Let $A = \{(x, y) \in \mathbb{R}^2 : y \geq 0, 2x \leq y \leq \sqrt{4 - (x-1)^2}\}$ and

$$B = \{(x, y) \in \mathbb{R} \times \mathbb{R} : 0 \leq y \leq \min\{2x, \sqrt{4 - (x-1)^2}\}\}.$$

Then the ratio of the area of A to the area of B is

Options

1. $\frac{\pi-1}{\pi+1}$

2. $\frac{\pi}{\pi-1}$

3. $\frac{\pi+1}{\pi-1}$

4. $\frac{\pi}{\pi+1}$

Question Type : MCQ

Question ID : 3666942075

Option 1 ID : 3666946414

Option 2 ID : 3666946416

Option 3 ID : 3666946415

Option 4 ID : 3666946413

Status : Not Answered

Chosen Option : --

Q.64

Let Δ be the area of the region $\{(x, y) \in \mathbb{R}^2 : x^2 + y^2 \leq 21, y^2 \leq 4x, x \geq 1\}$.

Then $\frac{1}{2} \left(\Delta - 21 \sin^{-1} \frac{2}{\sqrt{7}} \right)$ is equal to

Options

1. $\sqrt{3} - \frac{4}{3}$

2. $\sqrt{3} - \frac{2}{3}$

3. $2\sqrt{3} - \frac{1}{3}$

4. $2\sqrt{3} - \frac{2}{3}$

Question Type : MCQ

Question ID : 3666942076

Option 1 ID : 3666946420

Option 2 ID : 3666946419

Option 3 ID : 3666946417

Option 4 ID : 3666946418

Status : Not Answered

Chosen Option : --

Q.65 Let $[x]$ denote the greatest integer $\leq x$. Consider the function

$$f(x) = \max\{x^2, 1 + [x]\}. \text{ Then the value of the integral } \int_0^2 f(x) dx \text{ is}$$

Options

1. $\frac{8 + 4\sqrt{2}}{3}$

2. $\frac{1 + 5\sqrt{2}}{3}$

3. $\frac{5 + 4\sqrt{2}}{3}$

4. $\frac{4 + 5\sqrt{2}}{3}$

Question Type : MCQ

Question ID : 3666942080

Option 1 ID : 3666946435

Option 2 ID : 3666946433

Option 3 ID : 3666946436

Option 4 ID : 3666946434

Status : Answered

Chosen Option : 1

Q.66 If the vectors $\vec{a} = \lambda\hat{i} + \mu\hat{j} + 4\hat{k}$, $\vec{b} = -2\hat{i} + 4\hat{j} - 2\hat{k}$ and $\vec{c} = 2\hat{i} + 3\hat{j} + \hat{k}$ are coplanar and the projection of \vec{a} on the vector \vec{b} is $\sqrt{54}$ units, then the sum of all possible values of $\lambda + \mu$ is equal to

Options

1. 18

2. 0

3. 24

4. 6

Question Type : MCQ

Question ID : 3666942081

Option 1 ID : 3666946439

Option 2 ID : 3666946437

Option 3 ID : 3666946440

Option 4 ID : 3666946438

Status : Answered

Chosen Option : 4

Q.67 A light ray emits from the origin making an angle 30° with the positive x -axis. After getting reflected by the line $x + y = 1$, if this ray intersects x -axis at Q , then the abscissa of Q is

Options

1. $\frac{2}{3 - \sqrt{3}}$
2. $\frac{2}{3 + \sqrt{3}}$
3. $\frac{\sqrt{3}}{2(\sqrt{3} + 1)}$
4. $\frac{2}{(\sqrt{3} - 1)}$

Question Type : MCQ

Question ID : 3666942077

Option 1 ID : 3666946424

Option 2 ID : 3666946421

Option 3 ID : 3666946422

Option 4 ID : 3666946423

Status : Not Answered

Chosen Option : --

Q.68 Let $f : \mathbf{R} \rightarrow \mathbf{R}$ be a function such that $f(x) = \frac{x^2 + 2x + 1}{x^2 + 1}$. Then

- Options
1. $f(x)$ is one-one in $[1, \infty)$ but not in $(-\infty, \infty)$
 2. $f(x)$ is one-one in $(-\infty, \infty)$
 3. $f(x)$ is many-one in $(-\infty, -1)$
 4. $f(x)$ is many-one in $(1, \infty)$

Question Type : MCQ

Question ID : 3666942068

Option 1 ID : 3666946385

Option 2 ID : 3666946386

Option 3 ID : 3666946388

Option 4 ID : 3666946387

Status : Answered

Chosen Option : 2

Q.69 Let $y=f(x)$ be the solution of the differential equation $y(x+1)dx - x^2dy = 0$, $y(1) = e$. Then $\lim_{x \rightarrow 0^+} f(x)$ is equal to

- Options
1. e^2
 2. $\frac{1}{e}$
 3. $\frac{1}{e^2}$
 4. 0

Question Type : MCQ
 Question ID : 3666942086
 Option 1 ID : 3666946459
 Option 2 ID : 3666946458
 Option 3 ID : 3666946460
 Option 4 ID : 3666946457
 Status : Marked For Review
 Chosen Option : 2

Q.70 Consider the following system of equations

$$\alpha x + 2y + z = 1$$

$$2\alpha x + 3y + z = 1$$

$$3x + \alpha y + 2z = \beta$$

for some $\alpha, \beta \in \mathbb{R}$. Then which of the following is NOT correct.

- Options
1. It has no solution if $\alpha = -1$ and $\beta \neq 2$
 2. It has a solution for all $\alpha \neq -1$ and $\beta = 2$
 3. It has no solution for $\alpha = -1$ and for all $\beta \in \mathbb{R}$
 4. It has no solution for $\alpha = 3$ and for all $\beta \neq 2$

Question Type : MCQ
 Question ID : 3666942071
 Option 1 ID : 3666946398
 Option 2 ID : 3666946399
 Option 3 ID : 3666946397
 Option 4 ID : 3666946400
 Status : Not Attempted and Marked For Review
 Chosen Option : --

Q.71 Let $f(\theta) = 3\left(\sin^4\left(\frac{3\pi}{2} - \theta\right) + \sin^4(3\pi + \theta)\right) - 2(1 - \sin^2 2\theta)$ and

$S = \left\{ \theta \in [0, \pi] : f'(\theta) = -\frac{\sqrt{3}}{2} \right\}$. If $4\beta = \sum_{\theta \in S} \theta$, then $f(\beta)$ is equal to

Options

1. $\frac{5}{4}$

2. $\frac{11}{8}$

3. $\frac{9}{8}$

4. $\frac{3}{2}$

Question Type : MCQ

Question ID : 3666942083

Option 1 ID : 3666946445

Option 2 ID : 3666946448

Option 3 ID : 3666946447

Option 4 ID : 3666946446

Status : Not Answered

Chosen Option : --

Q.72 Let the tangents at the points $A(4, -11)$ and $B(8, -5)$ on the circle $x^2 + y^2 - 3x + 10y - 15 = 0$, intersect at the point C . Then the radius of the circle, whose centre is C and the line joining A and B is its tangent, is equal to

Options

1. $\frac{3\sqrt{3}}{4}$

2. $\sqrt{13}$

3. $\frac{2\sqrt{13}}{3}$

4. $2\sqrt{13}$

Question Type : MCQ

Question ID : 3666942079

Option 1 ID : 3666946429

Option 2 ID : 3666946430

Option 3 ID : 3666946431

Option 4 ID : 3666946432

Status : Answered

Chosen Option : 1

Q.73 Let α and β be real numbers. Consider a 3×3 matrix A such that $A^2 = 3A + \alpha I$. If $A^4 = 21A + \beta I$, then

- Options**
1. $\alpha = 1$
 2. $\beta = -8$
 3. $\beta = 8$
 4. $\alpha = 4$

Question Type : MCQ

Question ID : 3666942072

Option 1 ID : 3666946404

Option 2 ID : 3666946401

Option 3 ID : 3666946402

Option 4 ID : 3666946403

Status : Answered

Chosen Option : 1

Q.74 If p , q and r are three propositions, then which of the following combination of truth values of p , q and r makes the logical expression $\{(p \vee q) \wedge (\sim p \vee r)\} \rightarrow ((\sim q) \vee r)$ false?

- Options**
1. $p = T, q = F, r = F$
 2. $p = F, q = T, r = F$
 3. $p = T, q = F, r = T$
 4. $p = T, q = T, r = F$

Question Type : MCQ

Question ID : 3666942084

Option 1 ID : 3666946450

Option 2 ID : 3666946451

Option 3 ID : 3666946452

Option 4 ID : 3666946449

Status : Not Answered

Chosen Option : --

Q.75 Fifteen football players of a club-team are given 15 T-shirts with their names written on the backside. If the players pick up the T-shirts randomly, then the probability that at least 3 players pick the correct T-shirt is

- Options
1. $\frac{2}{15}$
 2. $\frac{1}{6}$
 3. $\frac{5}{36}$
 4. $\frac{5}{24}$

Question Type : MCQ
 Question ID : 3666942082
 Option 1 ID : 3666946444
 Option 2 ID : 3666946442
 Option 3 ID : 3666946441
 Option 4 ID : 3666946443
 Status : Answered
 Chosen Option : 2

Q.76 Let B and C be the two points on the line $y+x=0$ such that B and C are symmetric with respect to the origin. Suppose A is a point on $y-2x=2$ such that $\triangle ABC$ is an equilateral triangle. Then, the area of the $\triangle ABC$ is

- Options
1. $\frac{8}{\sqrt{3}}$
 2. $2\sqrt{3}$
 3. $\frac{10}{\sqrt{3}}$
 4. $3\sqrt{3}$

Question Type : MCQ
 Question ID : 3666942078
 Option 1 ID : 3666946426
 Option 2 ID : 3666946427
 Option 3 ID : 3666946428
 Option 4 ID : 3666946425
 Status : Marked For Review
 Chosen Option : 1

Q.77 Let $\lambda \neq 0$ be a real number. Let α, β be the roots of the equation $14x^2 - 31x + 3\lambda = 0$ and α, γ be the roots of the equation $35x^2 - 53x + 4\lambda = 0$.
Then $\frac{3\alpha}{\beta}$ and $\frac{4\alpha}{\gamma}$ are the roots of the equation

- Options**
1. $7x^2 + 245x - 250 = 0$
 2. $49x^2 + 245x + 250 = 0$
 3. $7x^2 - 245x + 250 = 0$
 4. $49x^2 - 245x + 250 = 0$

Question Type : MCQ
 Question ID : 3666942070
 Option 1 ID : 3666946395
 Option 2 ID : 3666946393
 Option 3 ID : 3666946396
 Option 4 ID : 3666946394
 Status : Not Answered
 Chosen Option : --

Q.78 Let $f(x) = x + \frac{a}{\pi^2 - 4} \sin x + \frac{b}{\pi^2 - 4} \cos x$, $x \in \mathbb{R}$ be a function which satisfies
 $f(x) = x + \int_0^{\pi/2} \sin(x+y) f(y) dy$. Then $(a+b)$ is equal to

- Options**
1. $-2\pi(\pi+2)$
 2. $-\pi(\pi-2)$
 3. $-2\pi(\pi-2)$
 4. $-\pi(\pi+2)$

Question Type : MCQ
 Question ID : 3666942074
 Option 1 ID : 3666946412
 Option 2 ID : 3666946409
 Option 3 ID : 3666946410
 Option 4 ID : 3666946411
 Status : Not Answered
 Chosen Option : --

Q.79 For two non-zero complex numbers z_1 and z_2 , if $\operatorname{Re}(z_1 z_2) = 0$ and $\operatorname{Re}(z_1 + z_2) = 0$, then which of the following are possible?

- A. $\operatorname{Im}(z_1) > 0$ and $\operatorname{Im}(z_2) > 0$
- B. $\operatorname{Im}(z_1) < 0$ and $\operatorname{Im}(z_2) > 0$
- C. $\operatorname{Im}(z_1) > 0$ and $\operatorname{Im}(z_2) < 0$
- D. $\operatorname{Im}(z_1) < 0$ and $\operatorname{Im}(z_2) < 0$

Choose the correct answer from the options given below:

- Options**
- 1. A and C
 - 2. B and D
 - 3. B and C
 - 4. A and B

Question Type : MCQ

Question ID : 3666942069

Option 1 ID : 3666946392

Option 2 ID : 3666946390

Option 3 ID : 3666946389

Option 4 ID : 3666946391

Status : Answered

Chosen Option : 3

Q.80 The domain of $f(x) = \frac{\log_{(x+1)}(x-2)}{e^{2\log_e x} - (2x+3)}$, $x \in \mathbb{R}$ is

- Options**
- 1. $\mathbb{R} - \{-1, 3\}$
 - 2. $(2, \infty) - \{3\}$
 - 3. $\mathbb{R} - \{3\}$
 - 4. $(-1, \infty) - \{3\}$

Question Type : MCQ

Question ID : 3666942067

Option 1 ID : 3666946382

Option 2 ID : 3666946381

Option 3 ID : 3666946384

Option 4 ID : 3666946383

Status : Not Answered

Chosen Option : --

Section : Mathematics Section B

Q.81 Let the coefficients of three consecutive terms in the binomial expansion of $(1+2x)^n$ be in the ratio 2 : 5 : 8. Then the coefficient of the term, which is in the middle of these three terms, is _____.

Given --
Answer :

Question Type : SA

Question ID : 3666942095

Status : Not Answered

Q.82 If all the six digit numbers $x_1 x_2 x_3 x_4 x_5 x_6$ with $0 < x_1 < x_2 < x_3 < x_4 < x_5 < x_6$ are arranged in the increasing order, then the sum of the digits in the 72th number is _____.

Given --
Answer :

Question Type : SA
Question ID : 3666942092
Status : Not Answered

Q.83 Suppose f is a function satisfying $f(x+y) = f(x) + f(y)$ for all $x, y \in \mathbb{N}$ and $f(1) = \frac{1}{5}$. If $\sum_{n=1}^m \frac{f(n)}{n(n+1)(n+2)} = \frac{1}{12}$, then m is equal to _____.

Given --
Answer :

Question Type : SA
Question ID : 3666942089
Status : Not Answered

Q.84 Let $f: \mathbb{R} \rightarrow \mathbb{R}$ be a differentiable function that satisfies the relation $f(x+y) = f(x) + f(y) - 1, \forall x, y \in \mathbb{R}$. If $f'(0) = 2$, then $|f(-2)|$ is equal to _____.

Given --
Answer :

Question Type : SA
Question ID : 3666942093
Status : Not Answered

Q.85 Let a_1, a_2, a_3, \dots be a GP of increasing positive numbers. If the product of fourth and sixth terms is 9 and the sum of fifth and seventh terms is 24, then $a_1 a_9 + a_2 a_4 a_8 + a_5 + a_7$ is equal to _____.

Given --
Answer :

Question Type : SA
Question ID : 3666942090
Status : Not Answered

Q.86 Let \vec{a}, \vec{b} and \vec{c} be three non-zero non-coplanar vectors. Let the position vectors of four points A, B, C and D be $\vec{a} - \vec{b} + \vec{c}, \lambda \vec{a} - 3\vec{b} + 4\vec{c}, -\vec{a} + 2\vec{b} - 3\vec{c}$ and $2\vec{a} - 4\vec{b} + 6\vec{c}$ respectively. If $\overline{AB}, \overline{AC}$ and \overline{AD} are coplanar, then λ is equal to _____.

Given --
Answer :

Question Type : SA
Question ID : 3666942091
Status : Not Answered

Q.87 Let the co-ordinates of one vertex of ΔABC be $A(0, 2, \alpha)$ and the other two vertices lie on the line $\frac{x+\alpha}{5} = \frac{y-1}{2} = \frac{z+4}{3}$. For $\alpha \in \mathbb{Z}$, if the area of ΔABC is 21 sq. units and the line segment BC has length $2\sqrt{21}$ units, then α^2 is equal to _____.

Given --
Answer :

Question Type : SA
Question ID : 3666942087
Status : Not Answered

Q.88 If the co-efficient of x^9 in $\left(ax^3 + \frac{1}{\beta x}\right)^{11}$ and the co-efficient of x^{-9} in $\left(ax - \frac{1}{\beta x^3}\right)^{11}$ are equal, then $(\alpha\beta)^2$ is equal to _____.

Given --
Answer :

Question Type : SA
Question ID : 3666942094
Status : Not Answered

Q.89 Let the equation of the plane P containing the line $x+10 = \frac{8-y}{2} = z$ be $ax+by+3z=2(a+b)$ and the distance of the plane P from the point $(1, 27, 7)$ be c . Then $a^2+b^2+c^2$ is equal to _____.

Given --
Answer :

Question Type : SA
Question ID : 3666942088
Status : Not Answered

Q.90 Five digit numbers are formed using the digits 1, 2, 3, 5, 7 with repetitions and are written in descending order with serial numbers. For example, the number 77777 has serial number 1. Then the serial number of 35337 is _____.

Given --
Answer :

Question Type : SA
Question ID : 3666942096
Status : Not Answered